

# Trimax S300 Series

## Industrial Applications - 50Hz

### RAMS

High purity alumina oxide ceramic or hardened stainless steel.

### BEARINGS

Spherical roller main journals with lead bronze small and big ends.

### GEARS

Precision ground steel to provide maximum life and optimum speeds.

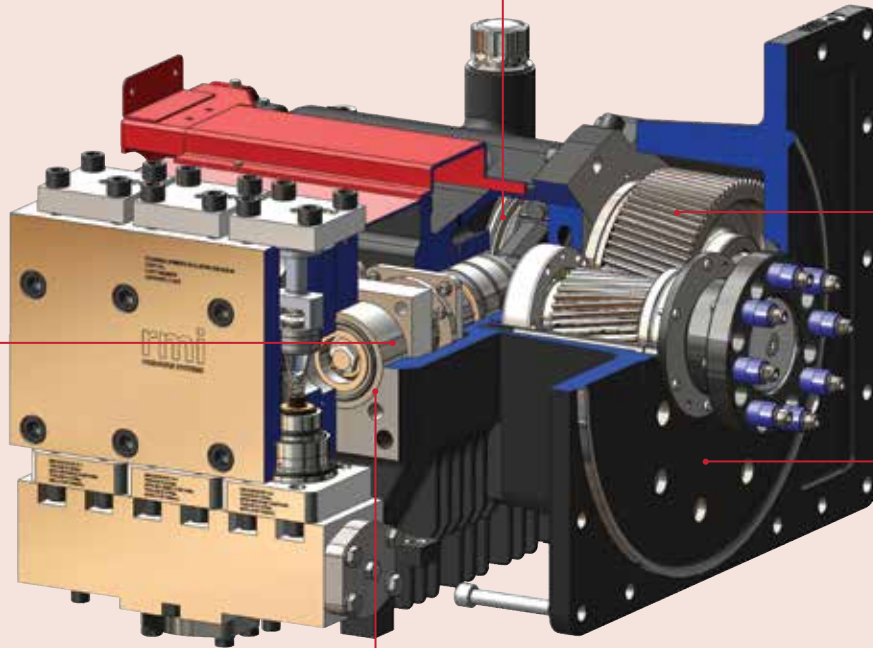

### VALVE LIFTERS (not shown)

Can be fitted as an optional extra for safe pressure control.

### GLAND PACKING

Self-adjusting spring loading packing, for maximum sealing.

### MOTOR

Flange mounted, on self aligning pedestal for trouble free installation.

The Trimax S200 series pump is specified to provide a safe and reliable supply of high pressure water or water based fluids in a variety of industries including mining, petrochemicals, power generation, metal processing and site services.

### PUMP GENERAL PERFORMANCE DATA

Flow	48 - 528 l/min	13 - 139 USgpm
Pressure	2,070 - 400 Bar	30,023 - 2,857 psi
Motor Power	185 - 225 kW	250 - 300 HP



### S300 PUMP DUTIES (190kW/300hp)

Motor Speed 1,475rpm  
Crank Speed 602rpm

RamØ	Pump Flow		Pump Pressure	
	mm	L/min	US gpm	BAR
50	208	55	400	5,802
55	252	66	400	5,802
60	300	79	355	5,149
62	321	85	329	4,772
65	352	93	298	4,322
70	404	107	258	3,742
75	465	123	224	3,249
80	528	139	197	2,857

### S350 PUMP DUTIES (185kW/250hp)

Motor Speed 1,475rpm  
Crank Speed 602rpm

RamØ	Pump Flow		Pump Pressure	
	mm	L/min	US gpm	BAR
24*	48	13	2,070	30,023
28	65	17	1,379	20,001
30	75	20	1,369	19,856
40	133	35	765	11,095
45	168	45	615	8,920

Mechanical efficiency 90%  
Volumetric efficiency 95%  
\*5 Bar inlet high boost required

### PUMP DIMENSIONS

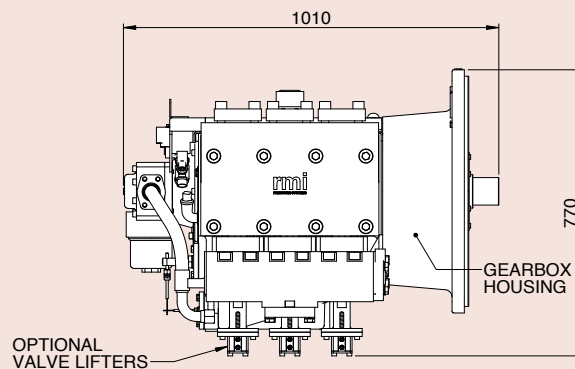
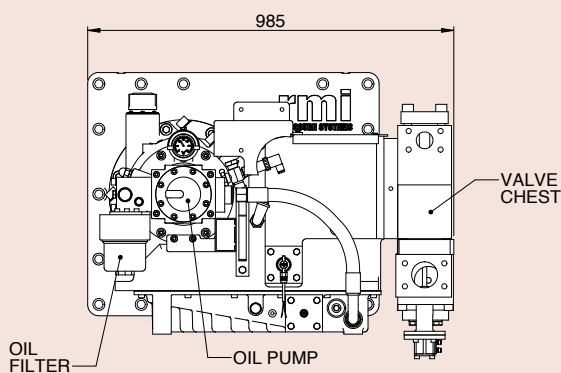

Note: Improvements in general design and modifications in detail will be embodied for the benefit of clients as and when introduced; consequently this specification is subject to alteration, as and when necessary, without notice.

#### HEAD OFFICE

RMI Pressure Systems  
1 Wolverton Street  
Manchester  
M11 2ET  
United Kingdom  
T: +44 (0)161 274 2451  
E: rmiinfo@armlink.com

#### AUSTRALIA OFFICE

RMI Pty. Ltd  
40 Aruma Place  
Cardiff  
NSW 2285  
Australia  
T: +61 (02)4954 0163  
E: sales@rmipsl.com.au

#### CHINA OFFICE

RMI Pressure Systems  
Room A050  
10th Floor Nexus Center  
No.19 East Third Ring Road  
Chaoyang Distring  
Beijing, China  
T: +86-15-65290-0513  
E: rmiinfo@armlink.com

#### USA OFFICE

RMI Inc.  
6599 Old Birmingham Highway  
Jasper  
Alabama 35501-8216  
United States  
T: +1 (205)483 0350  
E: sales@repowermining.com

[www.rmipsl.com](http://www.rmipsl.com)